

# RELAYS



GENERAL PURPOSE & POWER RELAYS



“Manufactured with Strict Quality and having undergone stringent Post-Production testing Procedures,

these relays meet the requirement of our customers. The fact that these relays are manufactured by

Salzer Electronics limited is your guarantee of quality and service.”



# Index

Plugin Relay MSP	4
Plugin Relay MSP with test button	6
Plugin Relays MKG/MKP with test button	8
Miniature Relay MSC/PCB	10
Medium Power Relay HSC/HSR	12
Power Relay PRC	14
Relay Module	17

## GENERAL PURPOSE MINIATURE Relays



**MSP - 2Pole**

Plug-in type Enclosed version  
with LED indication



**MSP -3Pole**

Plug-in type Enclosed version  
with LED indication



**MSP - 4Pole**

Plug-in type Enclosed version  
with LED indication

## SPECIFICATIONS

Contact Arrangement	2, 3 & 4 changeover contacts
Contact Ratings	5 Amps Resistive @ 240V AC/24V DC
Insulation Resistance	500 Meg. Ohms at 500 VDC
Mechanical Life	1 Million
Electrical Life	1 Lakh
Dielectric strength	As under
Between Contacts	1000V RMS
Between contact and coil	2000V RMS
Operate time at nominal voltage	< 20 m.secs
Release time at nominal voltage	< 10 m.secs
Coil Consumption	0.9W/1.2Va

## APPLICATIONS

Ideal for power & Sequence control  
Instrumentation, Industrial Controls &  
Automation Systems

## ADVANTAGES

LED Indication  
DIN RAIL mounting Socket &  
PCB socket options

## COIL DATA

Nominal Voltage DC & AC	Coil Resistance in Ohms + 10%		Pick-up Voltage (Max)	Release Voltage (Min)	
	DC	AC		DC	AC
06	41	13	4.8	0.6	1.8
12	165	53	9.6	1.2	3.6
18	330	-	14.4	1.8	5.4
24	660	210	19.2	2.4	7.2
48	2640	540	38.4	4.8	14.4
110	13200	4400	88	11	33
220	54000	-	176	22	72
240	54000	19000	192	22	72

All values at 25° ambient

### ORDERING INFORMATION

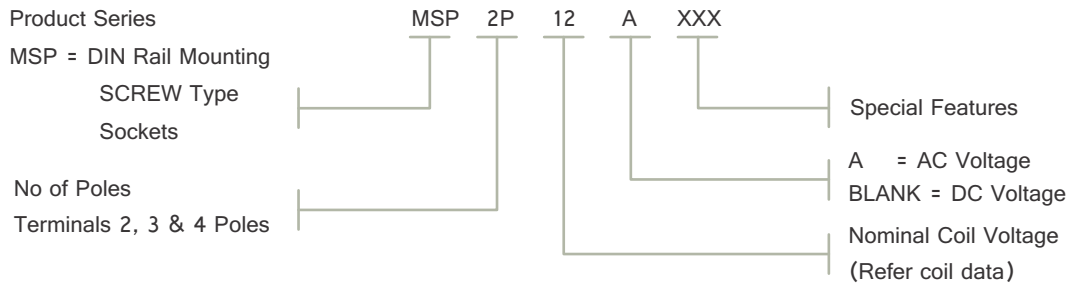

### DIMENSIONS

#### MSP RELAY - 2P ASSEMBLY

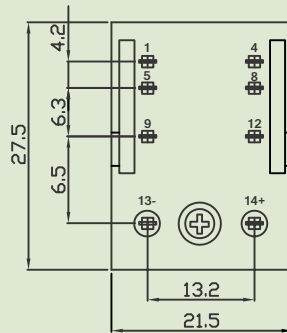
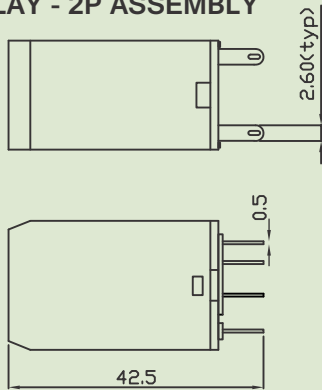

### WIRING LAYOUT (BOTTOM VIEW)

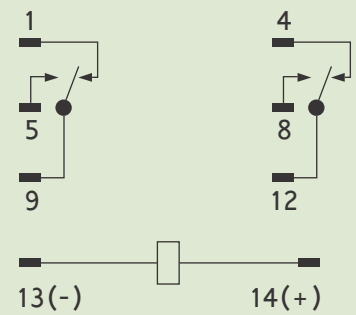

#### MSP RELAY - 3P ASSEMBLY

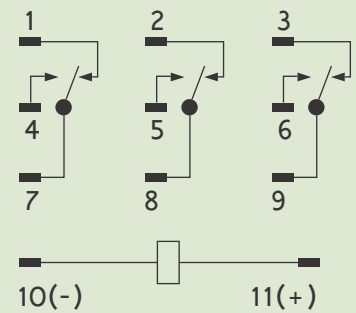
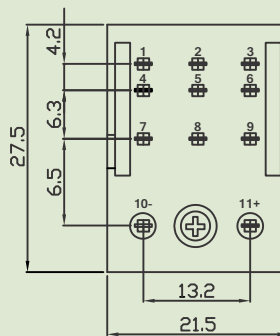
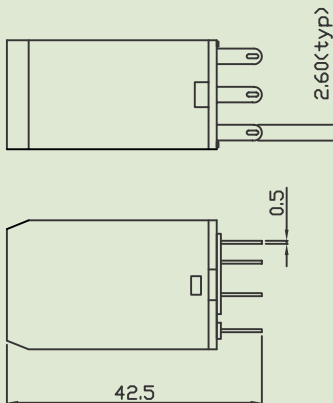

#### MSP RELAY - 4P ASSEMBLY

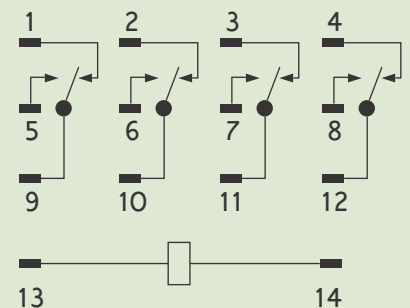
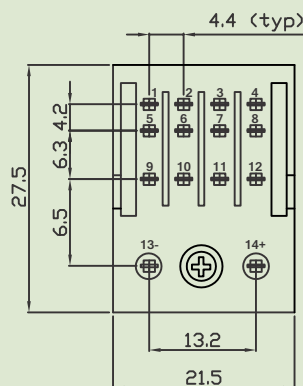
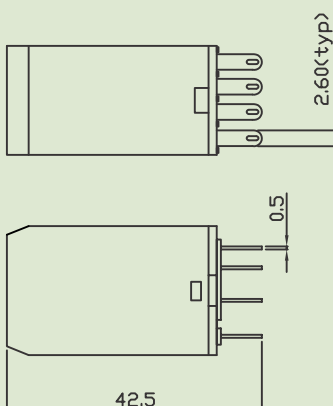

NOTE : PCB VERSION SOCKET AVAILABLE ON REQUEST

## GENERAL PURPOSE MINIATURE Relays. Mechanical Test Button &amp; Flag Indication

## Approvals



MSP - 2Pole (12Amps)

Plug-in type Enclosed version,  
LED indication with test Button



MSP - 4Pole (7Amps)

Plug-in type Enclosed version,  
LED indication with test Button

## SPECIFICATIONS

Contact Arrangement	2 & 4 changeover contacts
Contact Ratings	2 Pole-12Amps at 277VAC/30V DC 4 Pole-7Amps at 277VAC/30V DC
Insulation Resistance	500 Meg. Ohms at 500 VDC
Mechanical Life	1 Million
Electrical Life	1 Lakh
Dielectric strength	As under
Between Contacts	1500V RMS
Between contact and coil	1500V RMS
Operate time at nominal voltage	< 20 m.secs
Release time at nominal voltage	< 10 m.secs
Coil Consumption	0.9W/1.2Va

## APPLICATIONS

Elevator Control Panels,  
Ideal for power & Sequence control  
Instrumentation, Industrial Controls &  
Automation Systems

## ADVANTAGES

Mechanical Test Button,  
Flag Indication, LED Indication,  
DIN RAIL mounting Socket &  
PCB socket available

## COIL DATA

Nominal Voltage DC & AC	Coil Resistance in Ohms + 10%		Pick-up Voltage (Max)	Release Voltage (Min)	
	DC	AC		DC	AC
06	41	13	4.8	0.6	1.8
12	165	53	9.6	1.2	3.6
18	330	-	14.4	1.8	5.4
24	660	210	19.2	2.4	7.2
48	2640	540	38.4	4.8	14.4
110	13200	4400	88	11	33
120	-	-	-	-	-
220	54000	-	176	22	72
240	-	19000	192	22	72

\*Supplied with socket is UL marked & without socket is UR Marked

All values at 25° ambient

### ORDERING INFORMATION

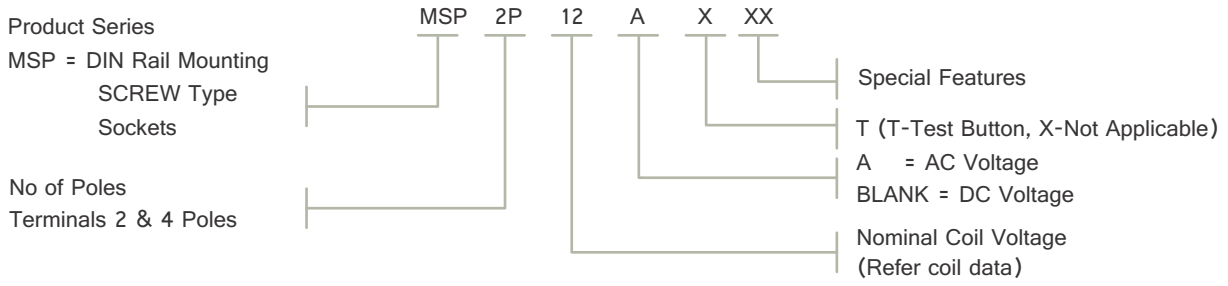

### DIMENSIONS

### WIRING LAYOUT (BOTTOM VIEW)

#### MSP RELAY - 2P ASSEMBLY

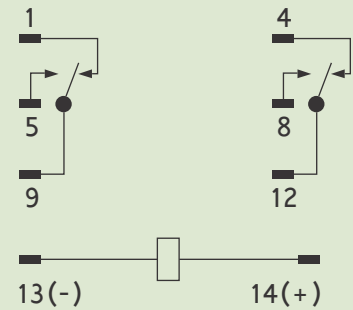
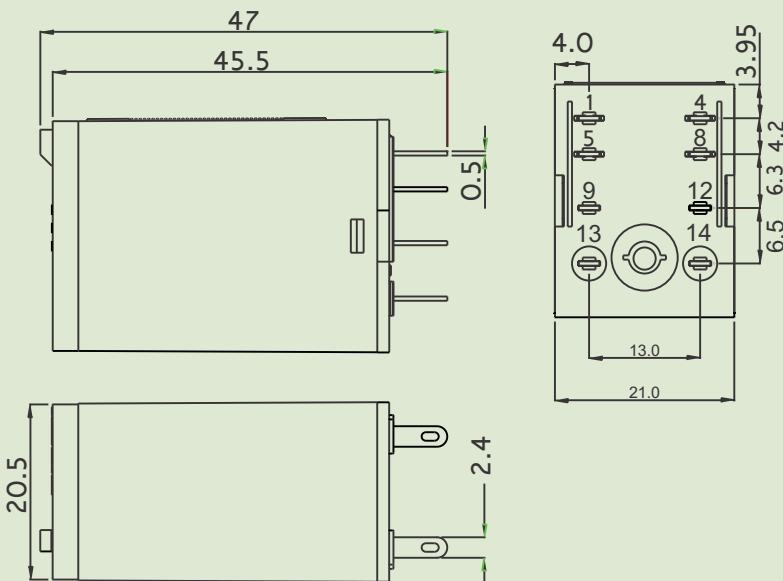

#### MSP RELAY - 4P ASSEMBLY

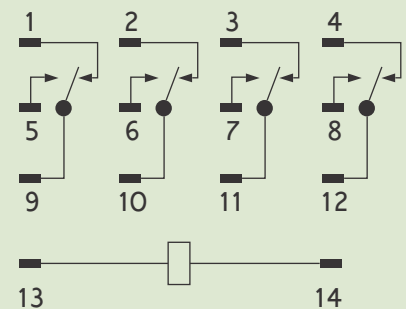
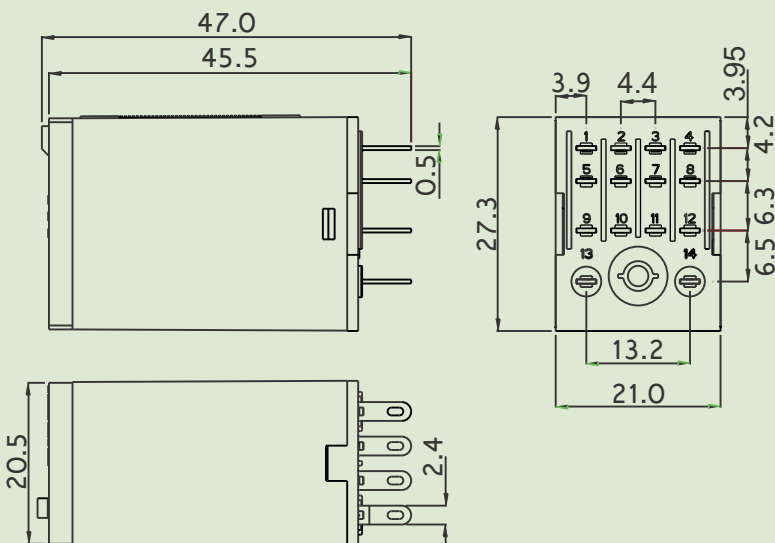

NOTE : PCB VERSION SOCKET AVAILABLE ON REQUEST

## MINIATURE Relays - Plug-in Relays



**MKG -5AMPS**

Plug-in type Enclosed version  
with LED indication



**MKP-10 AMPS**

Plug-in type Enclosed version  
with LED indication



**MKG-5AMPS / MKP-10 AMPS**

**Test Button Relay**

Plug-in type Enclosed version  
with LED indication

## SPECIFICATIONS

Contact Arrangement	1,2 or 3 changeover contacts
Contact Ratings	MKG 5 Amps Resistive at 240V AC/24V DC MKP 10 Amps Resistive at 240V AC/24V DC
Insulation Resistance	500 Meg. Ohms at 500 VDC
Electrical Life	1 Lakh Operations
Mechanical Life	1 Million Operations
Dielectric strength	As under
Between Contacts	1500V RMS
Between contact and coil	2000V RMS
Operate time at nominal voltage	< 20 m.secs
Release time at nominal voltage	< 10 m.secs
Coil Consumption	1.2 Watt / 2.4 VA

## APPLICATIONS

UPS, Inverter, Voltage stabilizers,  
Process Control systems,  
Instrumentation, Industrial Controls,  
Automation Systems,  
Vending Machines, Machine Tools,  
Textile Machineries &  
FRTU RTU/SCADA Panels

## ADVANTAGES

MKG/MKP Relays are PGCIL Approved  
Meeting JSS 50711/50703,  
IEC60255/ 61810 Specs

## COIL DATA

Nominal Voltage DC & AC	Coil Resistance in Ohms + 10%		Pick-up Voltage (Max)	Release Voltage (Min)	
	DC	AC		DC	AC
06	30	07	4.8	0.6	1.8
12	1P, 2P-200 / 3P-150	30	9.6	1.2	3.6
18	390	55	14.4	1.8	5.4
24	2P, 3P-500 / 1P-600	110	19.2	2.4	7.2
48	2250	440	38.4	4.8	14.4
60	3400	-	48	6.0	18
110	10K	2400	88	11	33
220	34K	-	176	22	72
240	-	9700	192	22	72

NOTE: For 220V DC Coil Voltage 45K Resistor Can be offered on Request

All values at 25° ambient



### ORDERING INFORMATION

**Product Series**

MKG = Plug - in Connection

MKP = Plug - in Connection

No of Poles

Terminals 1,2&3 Poles

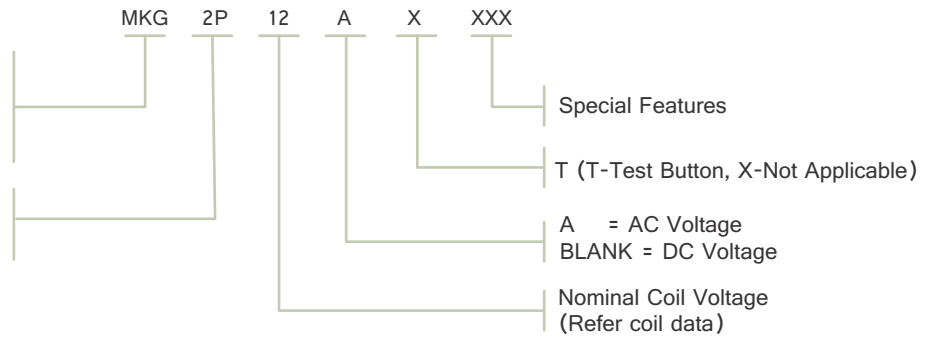

### DIMENSIONS

### WIRING LAYOUT (All Dimensions are in mm)

#### MKG/MKP

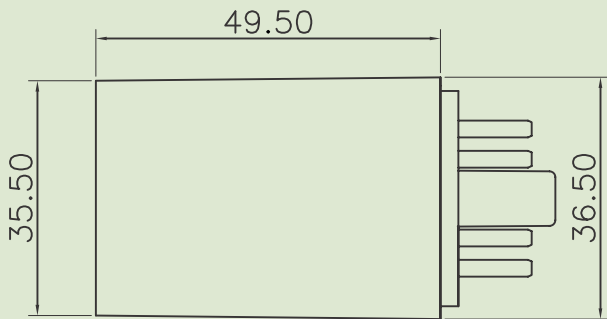

#### MKP-T

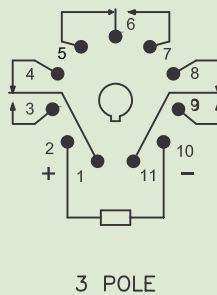
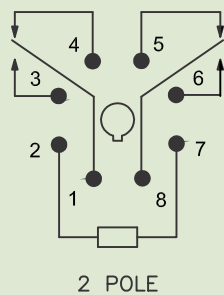
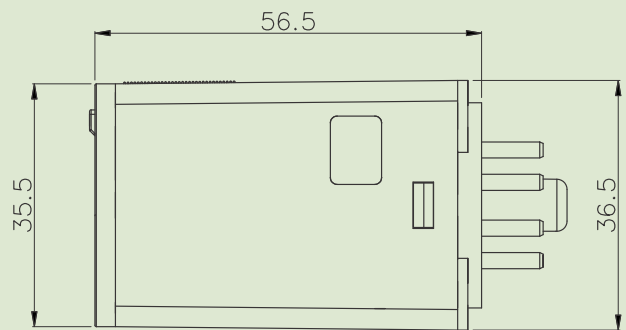

## MINIATURE Relays



**MSC (5 AMPS)**

Enclosed version Solder connection  
with LED indication 2 Poles



**TYPE PCB (5 AMPS)**

Enclosed version  
for PCB

## SPECIFICATIONS

Contact Arrangement	1,2 or 3 changeover contacts
Contact Ratings	MSC 5 Amps Resistive at 240V AC/24V DC PCB 5 Amps Resistive at 240V AC/24V DC
Insulation Resistance	500 Meg. Ohms at 500 VDC
Electrical Life	1 Lakh Operations
Mechanical Life	1 Million Operations
Dielectric strength	As under
Between Contacts	1500V RMS
Between contact and coil	2000V RMS
Operate time at nominal voltage	< 20 m.secs
Release time at nominal voltage	< 10 m.secs
Coil Consumption	1.2 Watt / 2.4 VA

## APPLICATIONS

UPS, Inverter, Voltage stabilizers,  
Process Control systems,  
Instrumentation, Industrial Controls,  
Automation Systems,  
Vending Machines & Machine Tools

## ADVANTAGES

Solder Connection  
Enclosed Version for PCB

## COIL DATA

Nominal Voltage DC & AC	Coil Resistance in Ohms + 10%		Pick-up Voltage (Max)	Release Voltage (Min)	
	DC	AC		DC	AC
06	30	07	4.8	0.6	1.8
12	1P, 2P-200 / 3P-150	30	9.6	1.2	3.6
18	390	55	14.4	1.8	5.4
24	2P, 3P-500 / 1P-600	110	19.2	2.4	7.2
48	2250	440	38.4	4.8	14.4
60	3400	-	48	6.0	18
110	10K	2400	88	11	33
220	34K	-	176	22	72
240	-	9700	192	22	72

NOTE: For 220V DC Coil Voltage 45K Resister Can be offered on Request

All values at 25° ambient

**ORDERING INFORMATION**

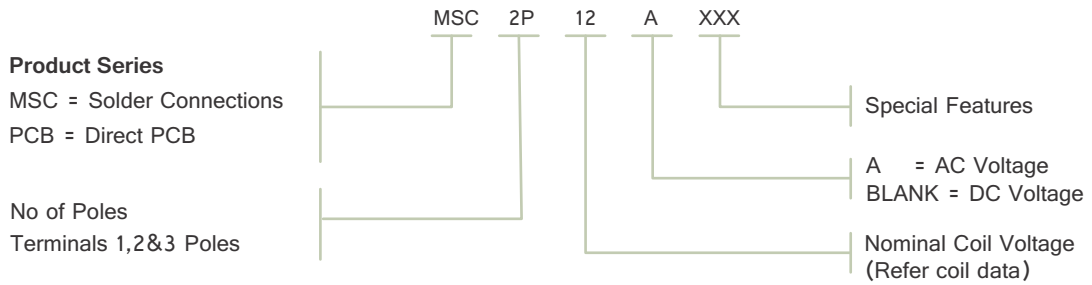

**DIMENSIONS**

**WIRING LAYOUT** (All Dimensions are in mm)

**For MSC Relays**

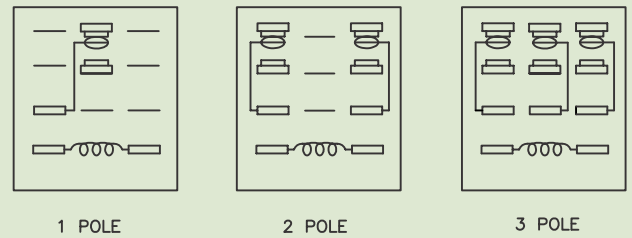
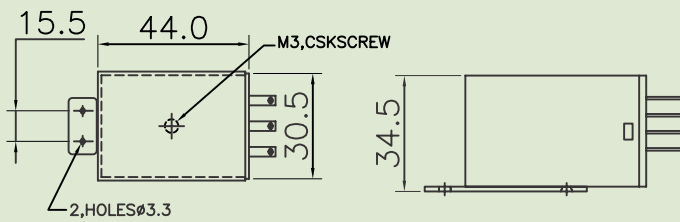

**For PCB Relays**

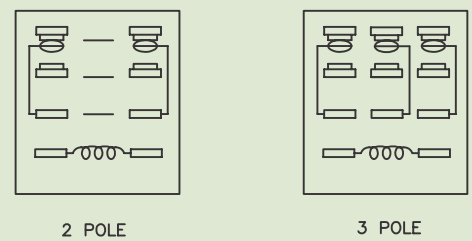
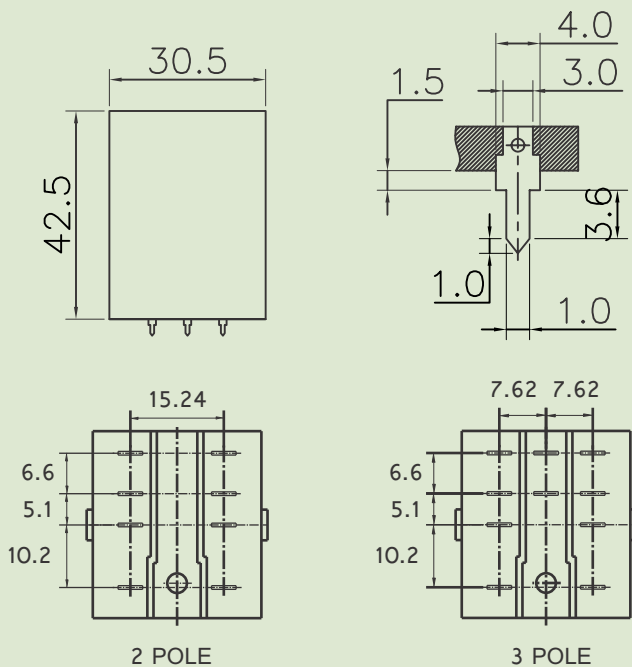

## MEDIUM POWER Relays •10 / 16 AMPS Resistive at 240VAC / 24VDC



**HSC (10 Amps)**

Enclosed version Solder connection



**HSR (16 Amps)**

Enclosed version Solder connection

### SPECIFICATIONS

Contact Arrangement	1,2 or 3 changeover contacts
Contact Ratings	10 / 16 Amps Resistive at 240V AC/24V DC
Insulation Resistance	500 Meg. Ohms at 500 VDC
Electrical Life	1 Lakh Operations
Mechanical Life	1 Million
Dielectric strength	As under
Between Contacts	1500V RMS
Between contact and coil	2000V RMS
Operate time at nominal voltage	< 25 m.secs
Release time at nominal voltage	< 15 m.secs
Coil Consumption	1.2 watts / 2.4 VA

### APPLICATIONS

Voltage Stabilizers

UPS

Control Panels

Control Systems

Industrial Controls

Air Conditioners

### ADVANTAGES

Elegant, Sturdy and light Weight

Versatile Relay satisfying

Low to Medium Power Sources

### COIL DATA

Nominal Voltage DC & AC	Coil Resistance in Ohms + 10%		Pick-up Voltage (Max)	Release Voltage (Min)	
	DC	AC		DC	AC
06	30	7	4.8	0.6	1.8
12	120	30	9.6	1.2	3.6
18	270	-	14.4	1.8	5.4
24	480	110	19.2	2.4	7.2
48	2250	-	38.4	4.8	14.4
110	10K	2400	88	11	33
220	34K	-	176	22	72
240	-	9700	192	22	72

NOTE: For 220V DC Coil Voltage 45K Resister Can be offered on Request

All values at 25° ambient

ORDERING INFORMATION

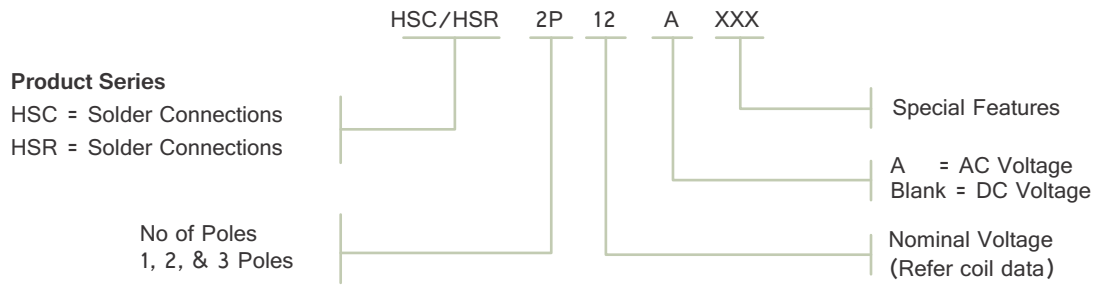

DIMENSIONS FOR HSC/HSR RELAYS

(All Dimensions are in mm)

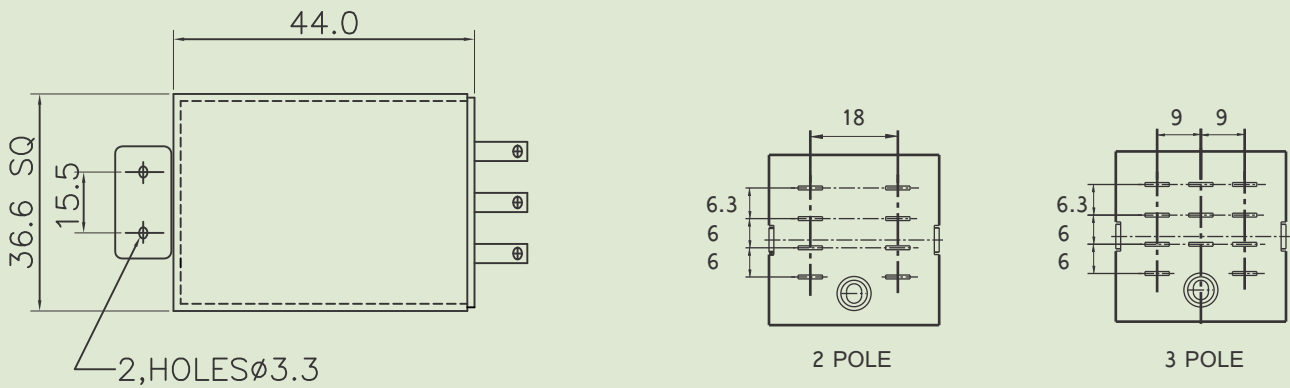

WIRING FOR HSC/HSR RELAYS

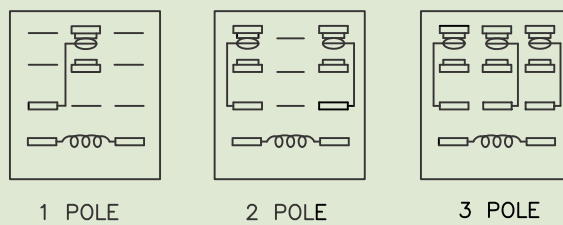

## POWER Relays



**PRC 30**  
(30 AMPS)

Enclosed Version Solder Terminal



**PRC 40**  
(40 AMPS)

Enclosed Version Screw Terminal



**PRC 60**  
(60 AMPS)

Enclosed Version Screw Terminal



**PRC 80/100**  
(80/100 AMPS)

Enclosed Version Screw Terminal

### APPLICATIONS

Inverter  
UPS  
Voltage stabilizer  
Automation Equipment  
Vending machines

### ADVANTAGES

High Reliability  
Solder & Screw Terminal  
40 Amps Metal Plate mounting/Dinrail mounting

## SPECIFICATIONS

S.No	Tech Data	PRC 30	PRC 40	PRC 60	PRC 80/100
1	Size (mm)	42 X 51 X 67	78 X 48 X 50	78 X 48 X 50	83 X 48 X 72
2	Contact capacity	AC 30A/240V DC 30A/24V	AC 40A/240V DC 40A/24V	AC 60A/240V DC 60A/24V	AC 80A / 100A / 240V DC 80A / 100A / 24V
3	Contact Arrangement	1P / 2P / 3P	1P	1P	1P
4	Electrical life - Operations	1 Lakh	1 Lakh	1 Lakh	1 Lakh
5	Mechanical life - Operations	1 Million	1 Million	1 Million	1 Million
6	Insulation resistance (milli ohms)	500 at 500V DC	500 at 500V DC	500 at 500V DC	500 at 500V DC
7	Dielectric Strength				
	Bet. Open Contacts	1500 VAC	1500 VAC	1500 VAC	1500 VAC
	Bet. Coil to Contact	2500 VAC	2500 VAC	2500 VAC	2500 VAC
8	Coil nominal Voltage	AC 240V / 24V DC 12V / 24V	AC 240V / 24V DC 12V / 24V	AC 240V / 24V DC 12V / 24V	AC 240V / 24VAC DC 12V / 24V
9	Coil nominal power	DC 2W	DC 2W	DC 2.5W	<3.5W

**ORDERING INFORMATION**

**Product Series**

- PRC = Solder Screw Terminals
- PRC 30
- PRC 40
- PRC 60
- PRC 80
- PRC 100

No of Poles  
1, 2, 3 Poles

PRC 2P 12 A XXX

Special Features

A = AC Voltage  
BLANK = DC Voltage

Nominal Voltage  
DC - 12, 24 VDC  
AC - 240VAC  
(other Coil Voltages on request)

**DIMENSIONS**

**WIRING LAYOUT**

**POWER RELAY 30AMPS**

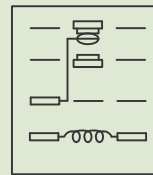
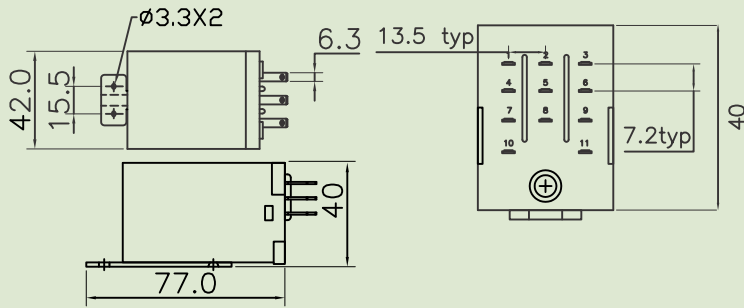

1 POLE

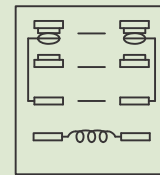

2 POLE

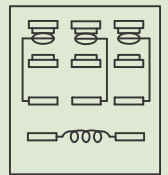

3 POLE

**POWER RELAY 40/60 AMPS**

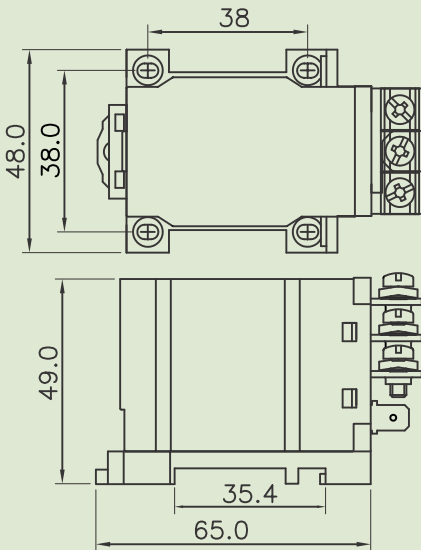

40AMPS  
8.80(TYP)

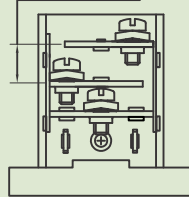

60AMPS

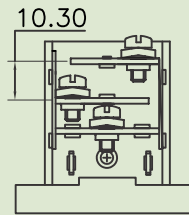

1 POLE

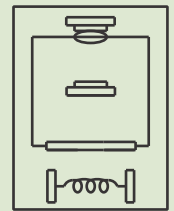

**POWER RELAY 80/100AMPS**

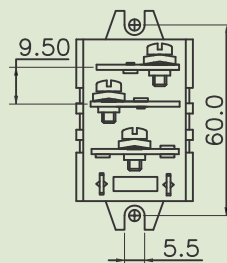
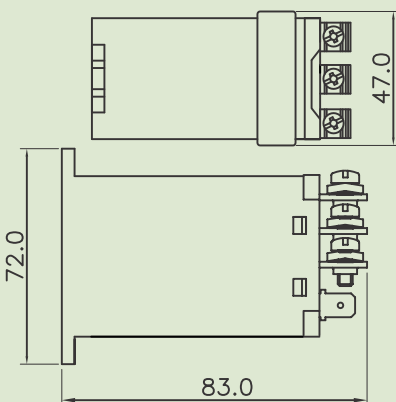

1 POLE

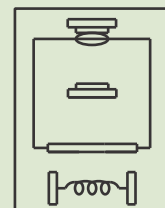

# Relay Modules





1 C/O Modules with Jumper for Coil Looping & Reverse Blocking Diodes



RMS021P24  
2 Channel Relay Module



RMS041P24  
4 Channel Relay Module



RMS081P24  
8 Channel Relay Module

2 C/O Modules with Jumper for Coil Looping & Reverse Blocking Diodes



RMS022P24  
2 Channel Relay Module



RMS042P24  
4 Channel Relay Module



RMS082P24  
8 Channel Relay Module

CIRCUIT DIAGRAM

1 Changeover

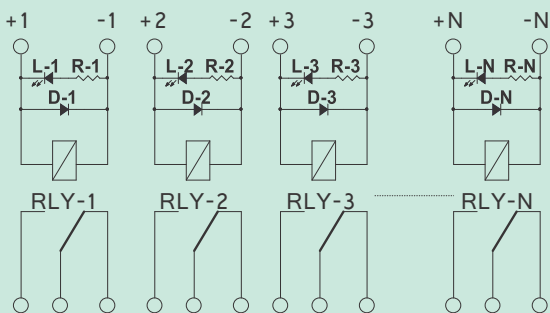

2 Changeover

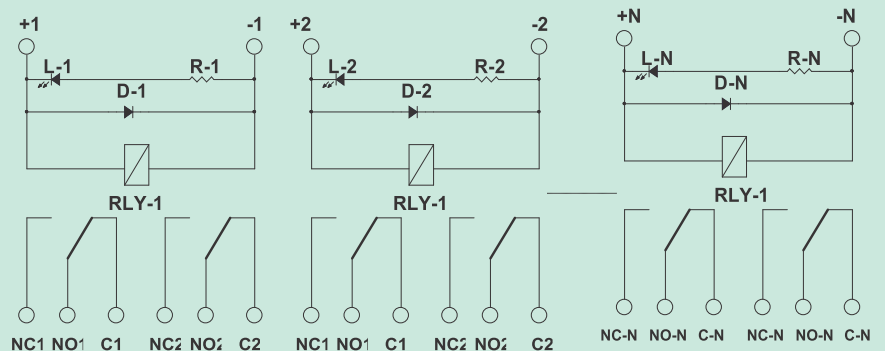

Number of Channels/Relay | 1+---N+Positive supply to relay coil | 1- ---N-Negative supply to relay coil | NO-N, C-N, NC-NRelay Contacts

No. of Channels	1C/O Module	Dimensions WxHxD(mm)	Dimensions WxHxD(mm) 110/230VAC
2	RMS021P24	36X85X60	39X85X70
4	RMS041P24	66X85X60	70X85X70
8	RMS081P24	135X85X60	145X85X70

No. of Channels	2C/O Module	Dimensions WxHxD(mm)	Dimensions WxHxD(mm) 110/230VAC
2	RMS022P24	55X85X65	55X85X70
4	RMS042P24	100X85X65	95X85X70
8	RMS082P24	185X85X65	185X85X70

**Features**

LED indication for relay ON status, Jumpers for commoning the + or - terminal of power supply, Reverse diode across relay coil to suppress coil switching noise

1C/O & 2C/O	1 Changeover			2 Changeover		
	2   4   8					
Nominal Coil Voltage	24VDC	110VAC	230VAC	24VDC	110VAC	230VAC
Must Operate Voltage	70% Max	80% Max	80% Max	70% Max	70% Max	70% Max
Dropout Voltage	15% Min	30% Min	30% Min	15% Min	15% Min	15% Min
Max-Coil Voltage	110% Max@70°	110% Max@70°	110% Max@70°	110% Max@70°	110% Max@70°	110% Max@70°
Coil Current/Channel (1)	40mA	15mA	8mA	40mA	15mA	8mA
Operate (Set) Time	15ms Max	15ms Max	15ms Max	15ms Max	15ms Max	15ms Max
Release (Reset) Time	5ms Max	10ms Max	10ms Max	5ms Max	10ms Max	10ms Max
Contact Rating	Relay	16A@30VDC/230VAC			5A@30VDC/230VAC	
	On Board	10A@30VDC/230VAC			5.3A@30VDC/230VAC	
Operating Ambient	0~55°C, 85%RH					
Storage Ambient	-20°C to 85°C					
Terminations	Coil	Screw type, for 2.5mm Sq.wire				
	Contact	Screw type, for 2.5mm Sq.wire				
Mounting	35mm DIN rail					
Endurance	Electrical: 100,000 Operations Min. (at 1800 Operation/hr)					
Max-Operating Frequency	Mechanical: 18000 Operations/hr   Electrical: 1800 Operations/hr					
Dielectric Strength	1. Coil to coil (When isolated): 100 VAC, 50/60Hz for 1 minute. 2. Coil to contacts: 2KVAC, 50/60Hz for 1 minute 3. Contacts of same polarity: 1KVAC, 50/60Hz for 1 minute 4. Contacts-Channel to Channel: 1.5KVAC, 50/60H for 1 Minute.					

Note:1. Current including LED current.

\*AC Coil Versions Available on request subject to availability.

**ORDERING INFORMATION**

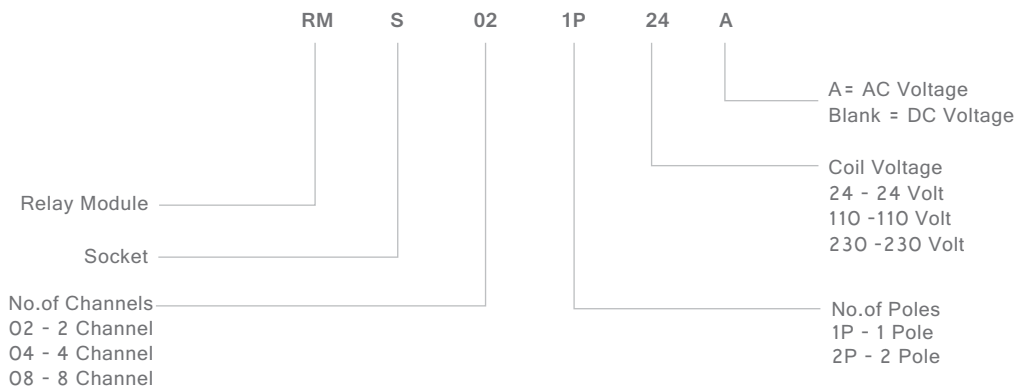

## Other Products

### Rotary Switches

AC Switch: 6 Amps - 400 Amps  
DC Switch: 16 to 500 Amps upto 250 V DC  
offered in various mounting options & custom built configuration switches



### Load Break Switches

Load Break (Isolator) range from 16 - 250 Ampere  
Changeover switches from 25 - 125 Amps upto 4 pole, offered with Sheet Steel, Aluminium & Plastic enclosures. IP65/NEMA rating.



### Photo Voltaic Isolators

DC Isolators : Range 25A to 63A upto 1000 VDC  
Standard Front Mounting, Door Interlock & Enclosure Mountings  
DC Changeover : Range 25A to 63A upto 1000 VDC  
Mounting Options : Standard Front Mounting, Door Interlock & Enclosure Mountings



### Cable Ducts

Wide range from (15x15mm) upto (150x150mm)  
Flame retardant UL94 V0 grade material,  
RoHS Compliant Ducts, offered in various colours & slotting styles



### Terminal Connectors

Range from 2.5 - 95 sq. mm  
Miniature, Double / Triple level connectors,  
Fuse, Ground, Disconnect, Distribution terminal Blocks & Screwless connectors



### Limit & Foot Switches

Available in Normal / Snap action  
Precision limit switches: 1NO + 1NC / 2NO + 2NC  
Operating force: From Light to Heavy duty applications, Versatile mounting heads, Rugged aluminum die cast housing, With Guard / Shielded version, Twin also available, Zinc die casting housing available on request



### Contactors & Overload Relays

Standard Contactors 9A to 105 Amps  
Mini Contactor from 7A to 16 Amps & Control Relay 16 Amps. Bimetallic Over Load Relay from 0.28-112 Amps, with a wide range of Accessories



### Motor Protection Circuit Breaker (MPCB)

In 32 & 63 Amps, Motor Disconnect function, Branch circuit protection, Motor control & Overload protection  
Relay range upto 63 Amps with UL listing



### Toroidal Transformers / Current Transformers

Single Phase 15VA - 30KVA & Three Phase 1KVA - 120KVA. CT's : Accuracy Class of 0.2 to 3 with burden of 5 to 30VA, Primary Current upto 4000A & Secondary of 5A / 1A



### Transformers & Chokes / Inductors / Reactors

Dry type Magnetics - VPI, AN - AF - Water Cooling etc.  
Transformers Range: 1KVA to 1MVA, 1Phase and 3Phase  
Chokes / Inductors / Reactors Range: 1KVAR to 1MVA 1Phase and 3 Phase



### Wires & Cables

Range from 0.5 sq mm to 300 sq mm  
Building Wires, Flexible Wires, Multi Core Cables, Flat Cables, HRFR, FRLS, ZHFR Wires, UL Rated Wires, Shielded & Braided Wires



### Lan Cables

Horizontal Cable specification testing Lab, UL listed - CM Flame Rating, ETL verified to ANSI/TIA-568.2-D Cat6, FR PVC, ROHS & REACH Compliance, Unshielded product Range is Cat5e, Cat6 & Cat6A, Shielded product Range is Cat5e, Cat6, Cat6A & Cat7, Jacket material is PVC/LSZH/PE



**salzer**

**Salzer Electronics Limited**

Registered & Corporate Office: Samichettipalayam, Coimbatore - 641 047, India.

Phone: +91 422 - 2692531, 4233600 Fax: +91 422 - 2692170

e-mail: [sales@salzergroup.com](mailto:sales@salzergroup.com) | [salzer@salzergroup.com](mailto:salzer@salzergroup.com)

[www.salzergroup.com](http://www.salzergroup.com)